

AKW
delivering independence

LUDA[®]

Safe Showering For All



LUDA[®]
AKW Intelligent Shower[®]



The Luda® Shower is an Electric Care Shower with numerous benefits for the end users

Q: *I have never used an electric shower heater before; is the Luda safe?*

A: The Luda® is an IP45 rated water proof shower unit (see No.5 on diagram opposite) which allows for worry free showering even if water splashes onto the unit & carries a comprehensive BEAB Care approval.

Q: *Is it designed with seated users in mind?*

A: The shape of the shower (see No.5 on diagram opposite) is tapered at the base to give more space in the enclosure for a seated user. You can choose a AKW Luda Twist with a lever at the base of the riser rail to twist the shower head angle & the shower unit can be positioned in reach. (see Luda Twist on page 3)

Q: *As a carer, is the shower head & shower hose retained?*

A: No, a non return valve (see No.11) means that no retainer is required giving the carer full use of the extra long shower hose. (No.13)

Q: *Is it suitable for users of varying abilities?*

A: A height adjustable shower head (see No.1), soap dish (No.8) & shelf (No.6) allow the height to be easily adjusted for seated or standing users. A 1 metre long riser rail (No.2) which doubles as a grab rail accommodates users of all heights whether standing or seated.

Q: *I have limited dexterity how would I use this shower?*

A: There is a lever (see No.3) to easily adjust the shower spray setting & push buttons to adjust the shower head (No.1) & soap dish height. (No.8)

Q: *Would the riser rail provide support if I grabbed onto it?*

A: Yes. The riser rail (see No.2) is in fact our fluted grab rail; so you do not need to clutter your shower with additional grab rails as the riser rail discreetly provides the extra support.

Q: *What ecological features does the Luda® have?*

A: The flow rate (see No.10) has three variable settings (high / med / low) to save water.

Q: *I can't bend down & stand up easily to reach my soap, is there a soapdish?*

A: Yes, the Luda® has a height adjustable soap dish (see No.8) & a shelf (No.6) & a hook (No.9) for shower gel or face cloth, to keep showering products accessible without creating tripping hazards.

Q: *What benefits are there for partially sighted users?*

A: The Luda® has audio beeps & LED illumination to let the user know when the power is on or off (No.12), & when temperature (No.7) & water flow (No.10) settings are changed. The Luda® has received RNIB accreditation & has tactile buttons with plus & minus symbols (No.4) for easy use.



Luda® can provide users of varying abilities with independent or assisted showering

1. Shower Head (5 spray patterns)
2. 1 Metre Riser Rail
3. Shower Spray Lever
4. Tactile Control Buttons
5. Shower Unit
6. Shelf
7. Audio & Illuminated Water Temperature Indicators
8. Soap Dish
9. Handy Hook
10. Audio & Illuminated Flow Rate Indicators
11. Non Return Valve
12. Start & Stop Button
13. 2 Metre Hose



Other Features:

- | Smooth curved & semi-matt aesthetically pleasing design minimizes glare & improves accessibility
- | Product is designed for easy cleaning
- | Riser rail fluted surface gives additional grip & can support up to 90kg
- | Connectivity to all AKW waste pumps with no additional flow switches or flow sensors
- | 2 Year warranty with extended options available
- | 10kW power gives a consistent all year round performance



Optional Luda Twist Features:

- | The Luda Twist is a special fluted grab rail offering added benefits to the seated user
- | The paddle lever normally locks the grab rail so it behaves like any other fixed grab rail, but when lifted (even with a clenched fist) the user can twist the rail to direct the shower head & spray just where they need it!
- | The paddle can also act as another soap dish
- | The Luda Twist main soap dish stays at the base of the rail & has added hooks for face cloth, soap or shampoo containers, keeping them accessible





Customer Recommendations:

'We are pleased to announce the AKW Luda® has completed a successful trial at our sheltered housing scheme in Dorset. The residents appreciated the easy to use features & safety aspects'

Housing 21

When asked for his comments on the Luda®, Ivan, a 73 year old with limited dexterity, said

'Just that it's absolutely brilliant!'

Ivan Webb

'Really impressed with the shower & thought it was a great product for our industry'

Local contractor

'Very happy with the performance & ease of use'

Social Housing Association Tenant

Kathleen, who has arthritis & has difficulty walking & using her hands, commented:

'The big buttons make it easy for me to use with a closed hand when my fingers are sore, it is very user-friendly & 10 times better than any other shower I have used'

Kathleen Ferguson

'When can we start buying it?!'

Senior Technical Officer at a Metropolitan Borough Council



IncLuda Kits & Pump Connections

IncLuda kits are available with all AKW digital pumps, kitted with pumped wastes without the need for a flow switch or sensor. Also available as an AKW Luda® IncLuda Twist.

			
<p>AKW DigiPump® M1 Waste Water Pump</p>	<p>AKW DigiPump® M2 Waste Water Pump Kit</p>	<p>AKW DigiPump® M3 Waste Water Pump</p>	<p>AKW DigiPump® 4 Waste Water Pump</p>
<ul style="list-style-type: none"> Pump & controller enclosed in one unit Max flow rate: 19 litres / min Non-handed unit (To fit left or right inlet) Satisfies BS7671 22mm inlet 	<ul style="list-style-type: none"> Pump & controller enclosed in one unit Non-handed unit (To fit left or right inlet) Satisfies BS7671 Max flow rate: 18-23 litres / min 32/22mm inlet 	<ul style="list-style-type: none"> Pump & controller enclosed in one unit Max flow rate: 16 litres / min Non-handed unit (To fit left or right inlet) Satisfies BS7671 22mm inlet 	<ul style="list-style-type: none"> Quiet in operation Pump & controller enclosed in one unit Max flow rate: 11 litres / min Non-handed unit (To fit left or right inlet) 15mm inlet Satisfies BS 7671 IP45

AKW Pump Connections

The following information has been extracted from the full installation instructions which must be followed when fitting this product

Make provision for the sensor cable to connect the pump to the shower (If Applicable).

Ensure the sensor cable is fed into the bottom entry of the shower & sealed by the safety seal cover.

Flow Sensor Connections - M Series Digi Pump & D4 Pump

- (- =) Black - connect flow switch wire Black to **F+**
- (S =) White - connect flow sensor wire Brown to **F-**
- (+ =) Red - connect flow sensor wire Red to **S2**

Flow Switch Connections - Manual Pump

Archimedes 4 & 4F

- (- =) White - connect flow switch wire to **S2**
- (+ =) White + connect flow switch wire to **S1**

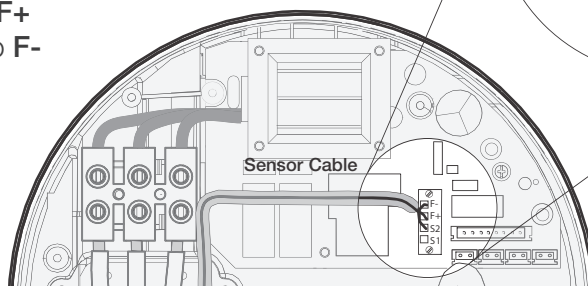
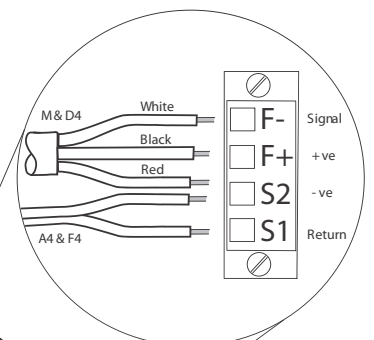



Luda® Accessories

Versability® Grab Rails & AKW 2000 series Hanging Shower Seat



Option 1: Alcove Grab Rail Kit



Option 2: Corner Grab Rail Kit



Option 3: Extended Grab Rail Kit

Versability® Grab Rails available to assist independent showering

Feature:

- | Fluted grab rail configurations providing assistance throughout the showering area
- | Vertical riser bar allows the height of the shower head to be adjusted to each user
- | Height adjustable soap dish & shelf can be fitted (optional)
- | Fluted heavy duty grab rails for improved grip
- | Made from high quality uPVC

AKW 2000 series Hanging Shower Seat

Features:

- | Adjustable legs cover a wide range of heights making it suitable for a child or adult user
- | Seat locks to Versability® grab rail system
- | Easily removable
- | Comfortable & rustproof
- | Compact option designed for smaller enclosures





SPECIFICATION	AKW LUDA
Power	10kW (9.2kW)
Operating Water Pressure Range	Min= 0.5 bar Max= 10 bar
Flow Settings	Low= (3.5 l/min) Medium= (5.0 l/min) High= (6.5 l/min)
Max Temperature During Operating (set by DIP switch)	41 / 43 / 46 (digitally set)
Low Pressure / Low Flow Indication	✓
Over - Temperature Indication	Top Power Led Flashes
Automatic Shut-Down	After 30 minutes
Immediate Manual Restart after Automatic Shut-Down	✓
BEAB Care Mark Certified	✓
BEAB Approved	✓
RNIB	✓
BEAB EMC	✓
KIWA Approved	✓
WRAS Approved	✓
Dust / Water Ingress Rating	IP 45
Phased Shut-Down	✓
Water Pipe Entry Points	Bottom, Top & Back
Electric Cable Entry Points	Top & Back
Pipework Fitting	15mm John Guest Speedfit®
Flow Meter Connection For Pumps	✓ (Variable & Switched flow)
Guarantee Period	2 year warranty with extended options available
Min / Max Ambient Water Temperature	Min= 2°C Max= 28°C
Double Check Valve Incorporated	✓
Power On Indicator	✓
Start-Up Modes	✓
Remote Control Of Shower head with Luda Twist Accessory	✓
Shower Head Usability	✓
Riser Rail Strength	✓
Soap Dish	✓
Riser Rail & Fittings	✓

Accreditations:



RISER RAIL
DOC M COMPLIANT



delivering independence®

www.akwmedicare.co.uk

AKW Medi-Care Ltd • Pointon Way • Hampton Lovett • Droitwich Spa • WR9 0LR
 Order Line: 01905 823 299 General Enquiries: 01905 823 298 Fax: 01905 823 297
 E-Mail: sales@akw-medicare.co.uk

